



ELTON
LIGHTING

Lighting your ways..

ROBUST SQ

RECESSED DOWN LIGHT



IP65 **PF 0.9** **CRI ≥80** **CE** **RoHS** 



ROBUST RD is ELTON 's Recessed square spotlight designed with high quality light and superior efficiency. Luminaire body made of die-cast aluminum and PMMA diffuser for interior architecture lighting.

Features

- > No UV/IR light.
- > Environment friendly, without Mercury or any other hazardous substances.
- > Up to 70% energy saving compared to standard CFL.

Application Areas

It is designed for general lighting applications in office, supermarket, shop, school, hotel, etc. It is also widely used for public areas, such as stairway, lobby, reception, corridors etc.

Dimensions

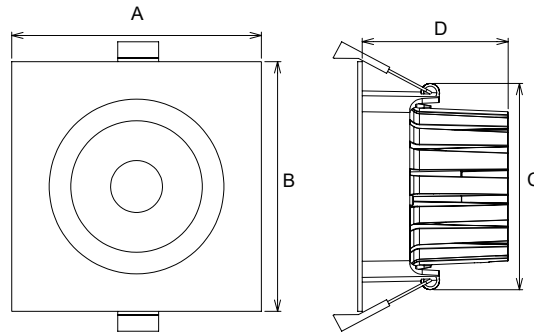

Code	Dimension(mm)				Cut Out
	A	B	C	D	
80	80	80	68	40	Ø68-72
90	90	90	75	49	Ø75-80
110	110	110	90	64	Ø90-95

Parameters

Power (W)	Size (ØxH)	Lumens (Non-DIM) (Lm)	Lumens (DIM) (Lm)
5	80x40	465-530	455-520
8	80x40	695-815	685-805
10	90x49	860 -1000	850- 990
10	110x64	860 -1000	850 - 990
13	110x64	1130 - 1300	1120-1290

AC Input Range	200-240 V (50/60Hz)
LED	SMD
CRI	>80
Installation	Recessed
CCT Range	2700K,3000K, 4000K, 5000K
Beam Angle	36°/60°
Protection Class	Class II
Lifetime(Hr)	50,000h
Working Temp.	-20 to +45°C
Storage Temp.	-20 to +65°C
Ingress Protection	IP65
LED Driver	Built -out
Warranty	5 years

Ordering Info.

